

Development and Deployment of Virtual Test Systems

An enabler to faster and efficient vehicle development

Muralidharan Chennakrishnan
Vehicle Dynamics Attribute Engineering
Ashok Leyland Product Development

MATLAB EXPO 2018
INDIA
19 April | Bangalore
24 April | Hyderabad
26 April | Pune





Objective

Vehicle development and engineering the vehicle dynamics

Overview of testing for vehicle dynamic simulations

Status quo and challenges

Approach to virtual test system

Workflow of virtual system

The solution

Benefits



- ❑ Develop and deploy the methodology of virtual testing for vehicle dynamics.
- ❑ The new system to be parametric, capable to predict key parameters of interest to vehicle dynamics analyses.
- ❑ Adept in sustainable utilization through the life cycle of vehicle and enable optimization & automated testing.



Vehicle development and engineering the vehicle dynamics - process

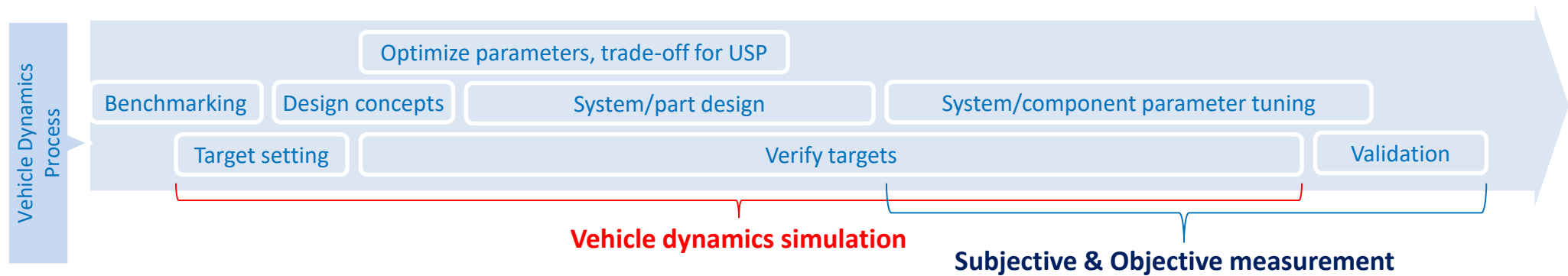
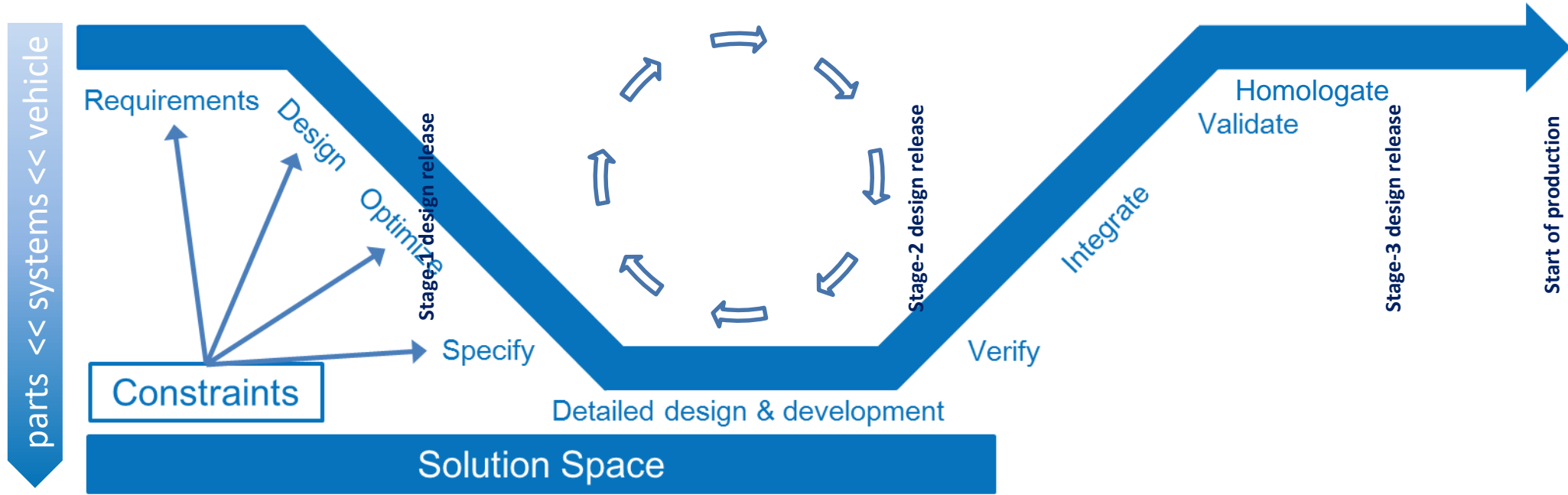

Vehicle dynamics simulation process

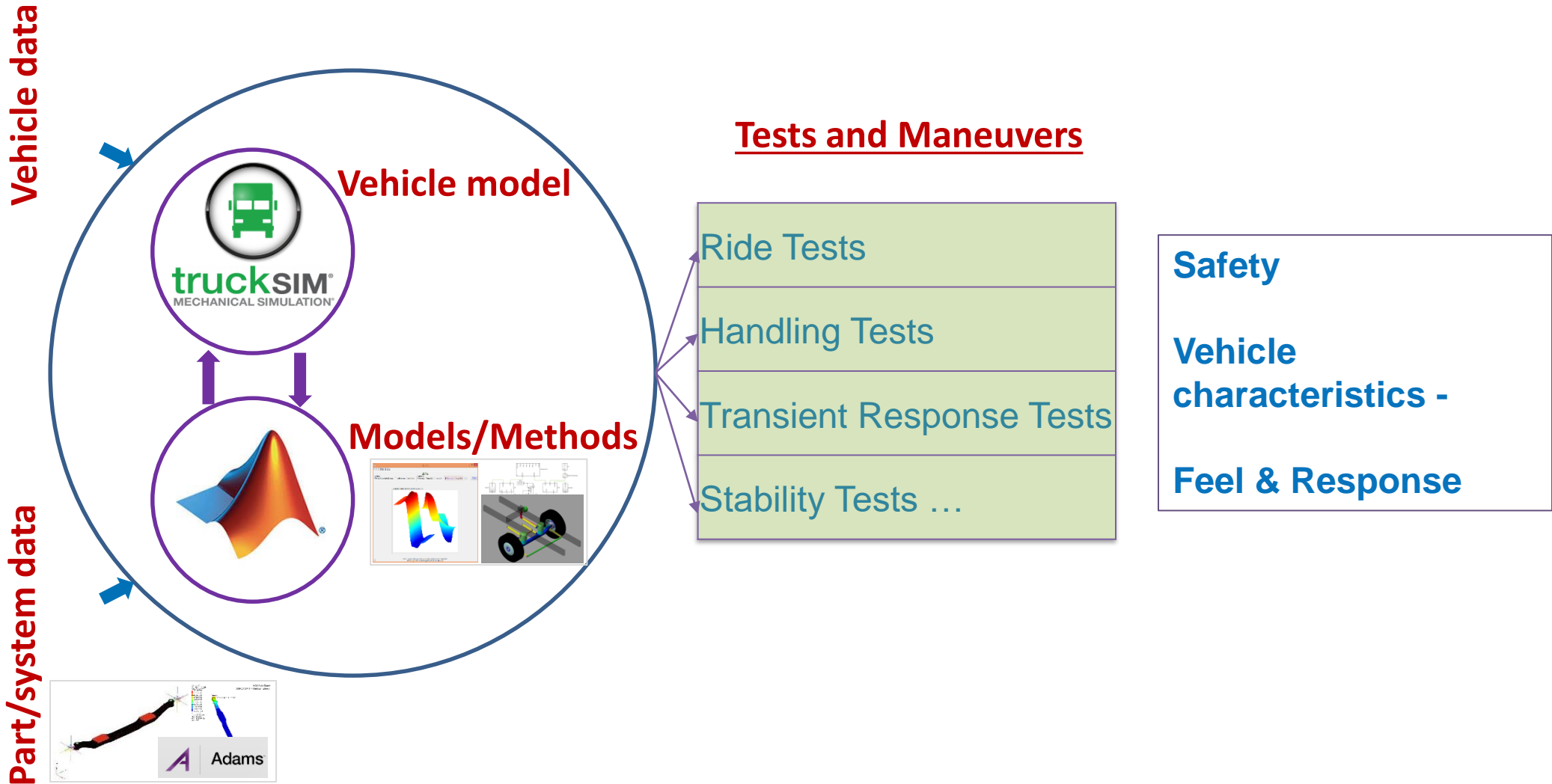

Overview of testing for vehicle dynamics simulation and its inputs



- ❑ Apart from development and tuning tests of vehicle, specific rig tests of vehicle and its systems are needed for useful vehicle dynamic simulations.
- ❑ Traditionally this tests are done with huge special purpose machines.
- ❑ A complete physical vehicle is loaded on the machine. Depending on the type of machine either all the tires or vehicle chassis are fixed to ground.
- ❑ Depending on the type of fixing(tires or chassis), 3-directional load and torque is applied in defined sequences.
- ❑ Forces, moments and deflections are measured at various points in the vehicle and vehicle systems to generate required parameters.

An effective TruckSIM model needs to have significant parameters for useful results



Axle dive: Dive table
No Caster Change
Axle X movement: Longitudinal Movement
No movement (R = 0)
Axle Y movement - jounce: Lateral Movement
No movement
Axle Y movement - roll: Lateral Movement
Roll Center: 53 mm Below Axle

Kinematic Properties

Nominal steering gear ratio: deg/deg

Speed Effect: Steer Gain vs. Speed
Always Steered

Define steer angles in vehicle coordinates

Left Wheel Kinematics: Steering kinematics
Left Wheel, 5 m Wheelbase

Right Wheel Kinematics: Steering kinematics
Right Wheel, 5 m Wheelbase

Ground-Friction Low-Speed Steer Torque

Left Side: Parking Torque
Zero

Right Side: Parking Torque
Zero

Steering Compliance

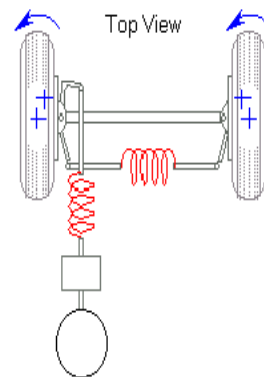

Steer left wheel

Tie rod compliance: right-wheel steer relative to left wheel due to right-wheel kingpin moment:

deg/N-m

Steering column compliance: steer of both wheels due to kingpin moments on both wheels:

deg/N-m

Kingpin Geometry

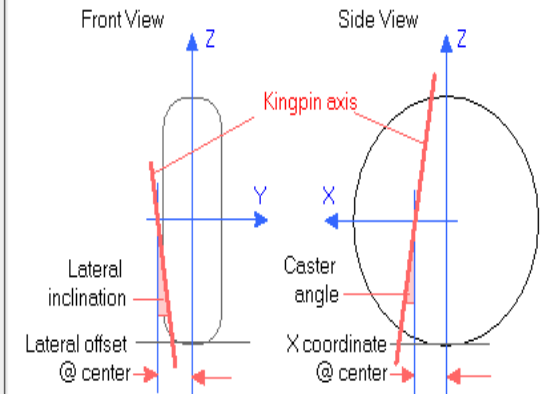

Compliance Coefficients

	Left	Right	
Toe vs Fx:	<input type="text" value="0"/>	<input type="text" value="0"/>	deg/N
Steer vs Fy:	<input type="text" value="0"/>	<input type="text" value="0"/>	deg/N
Steer vs Mz:	<input type="text" value="0"/>	<input type="text" value="0"/>	deg/(N-m)
Camber vs Fx:	<input type="text" value="0"/>	<input type="text" value="0"/>	deg/N
Inclination vs Fy:	<input type="text" value="0"/>	<input type="text" value="0"/>	deg/N
Inclination vs Mz:	<input type="text" value="0"/>	<input type="text" value="0"/>	deg/(N-m)
Axle longitudinal vs Fx	<input type="text" value="0"/>		mm/N
Axle lateral vs Fy	<input type="text" value="0"/>		mm/N

Axle Interactions

Axle wrap compliance: deg/N-m

Ratio: steer / wrap: deg/deg

Wheel steer vs. axle jounce: deg/mm

	Left	Right	
Lateral offset @ center:	<input type="text" value="xx"/>	<input type="text" value="xx"/>	mm
Lateral inclination:	<input type="text" value="xx"/>	<input type="text" value="xx"/>	deg
X coordinate @ center:	<input type="text" value="xx"/>	<input type="text" value="xx"/>	mm
Caster angle:	<input type="text" value="xx"/>	<input type="text" value="xx"/>	deg



- ❑ Specialized vehicle dynamics test rigs for heavy trucks and buses are rare, globally.
- ❑ Building specialized rig (for vehicle dynamics parameter measurement) for heavy commercial vehicle is economically unviable due to huge capital, time and less than optimum facility utilization for single OEM.
- ❑ Commercial virtual test systems specifically for truck & bus configurations are not yet mature.
- ❑ Multibody simulations with existing commercial tools need expertise, detailed vehicle model and relatively more time apart from computationally expensive.
- ❑ There is need for seamless integration of virtual test system simulation and truckSIM simulations for faster throughput.
- ❑ Current scenario of vehicle development demands hundreds of vehicle configurations to be designed to deliver preset vehicle dynamics performance target.
- ❑ In upfront simulations and design tuning, the importance of correct parameters input can't be overstated.

Approach to virtual test system



- Physical modelling using Simscape 'Multibody' methodology is made use for the development of virtual test system.

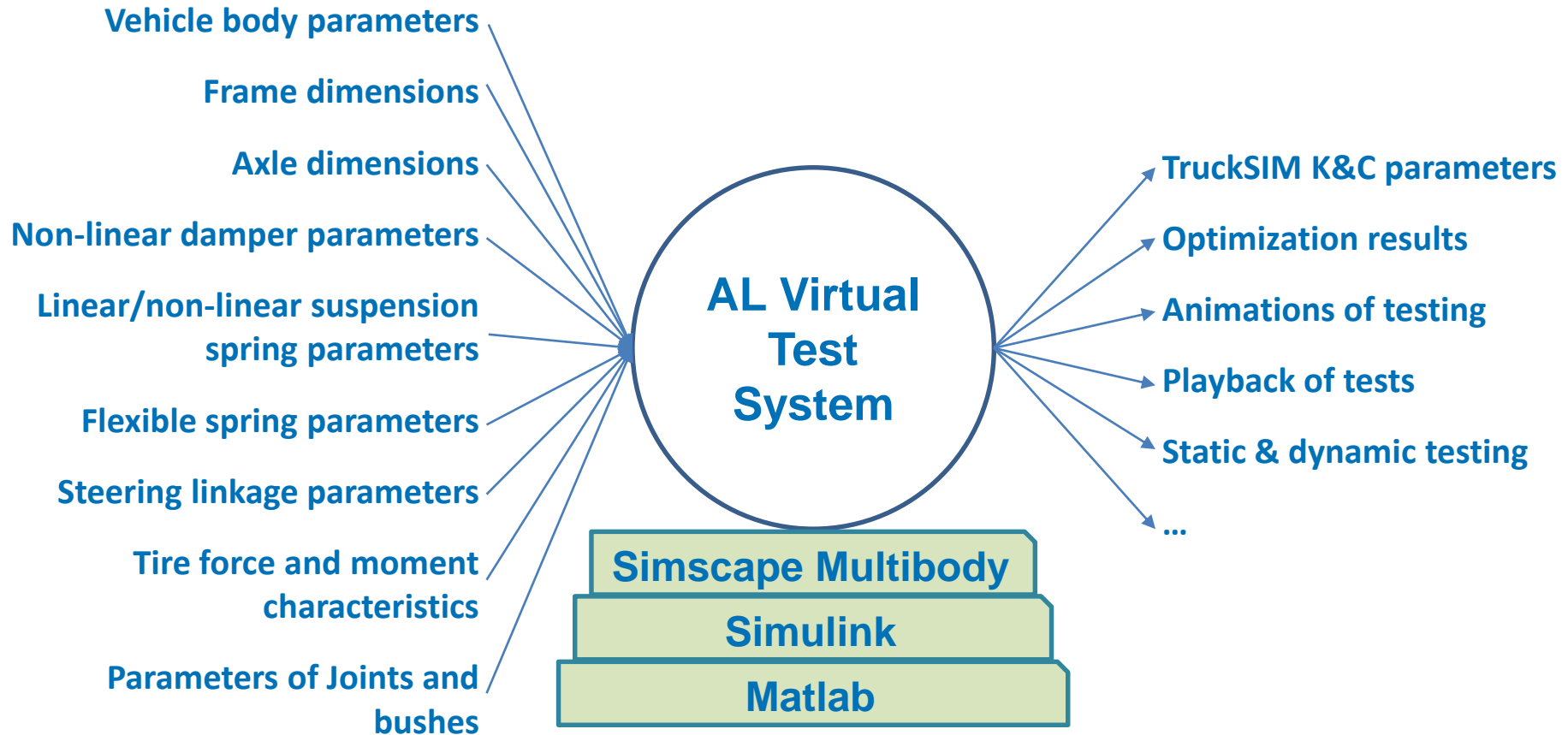

Virtual test system workflow

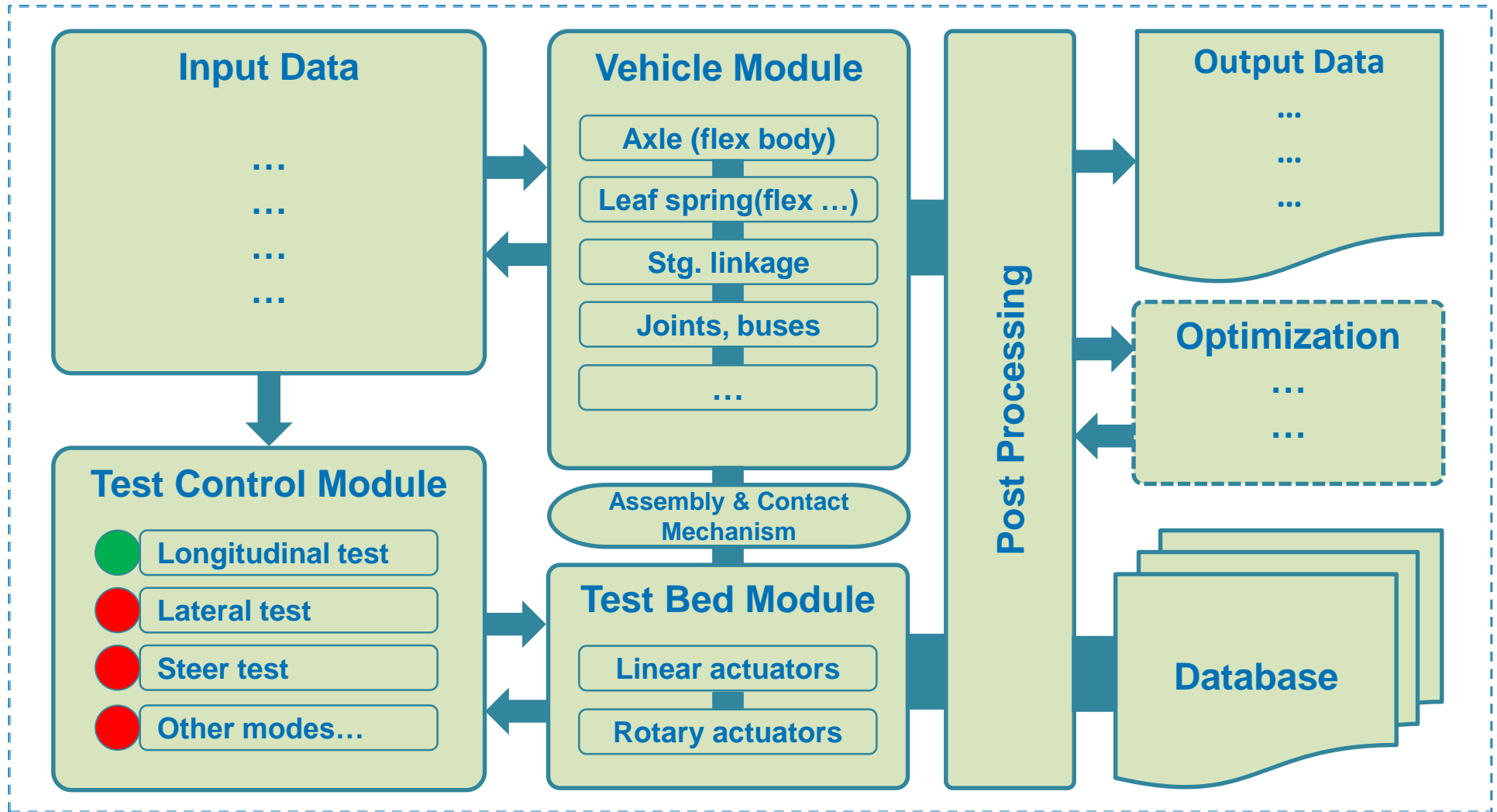



Deployment to user group

- ❑ Virtual test system developed in simscape toolboxes are being converted to standalone executables with suitable GUI using MATLAB and Simulink coder tool boxes.
- ❑ Such standalone .exe files installed in different user PCs enable various pre-defined tests be performed by vehicle dynamics engineers.
- ❑ Thus, wide use of virtual test system by domain engineers for various vehicle projects result in effective upfront engineering.

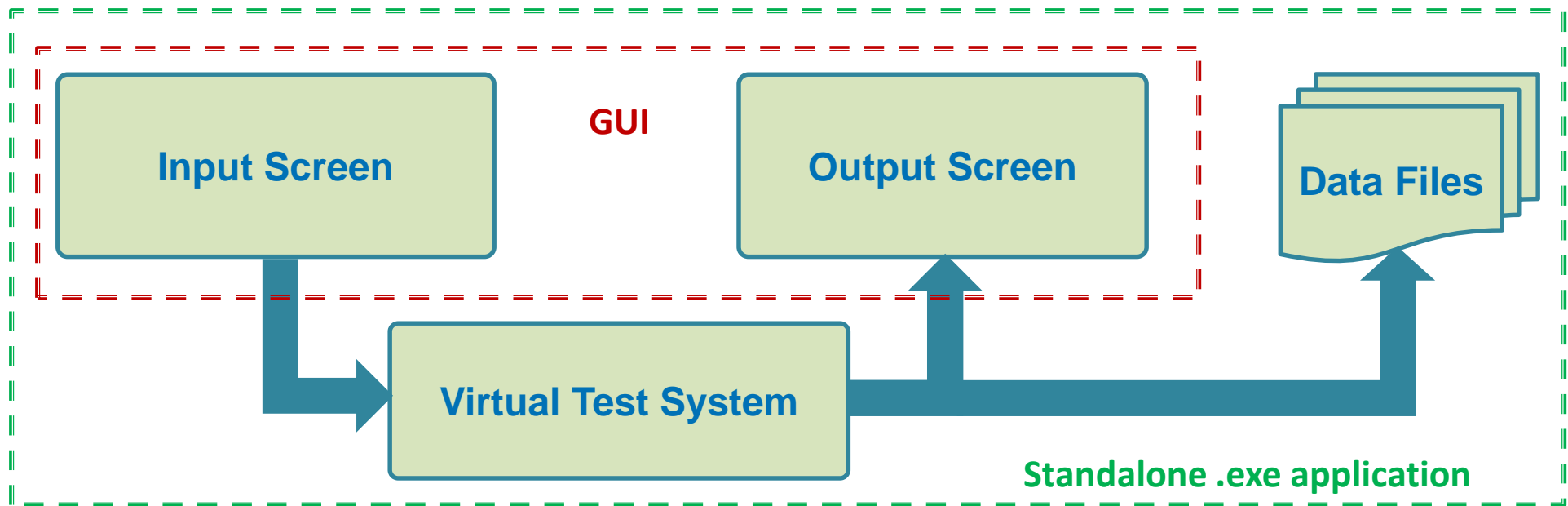

The solution: Virtual test system by Simscape Multibody

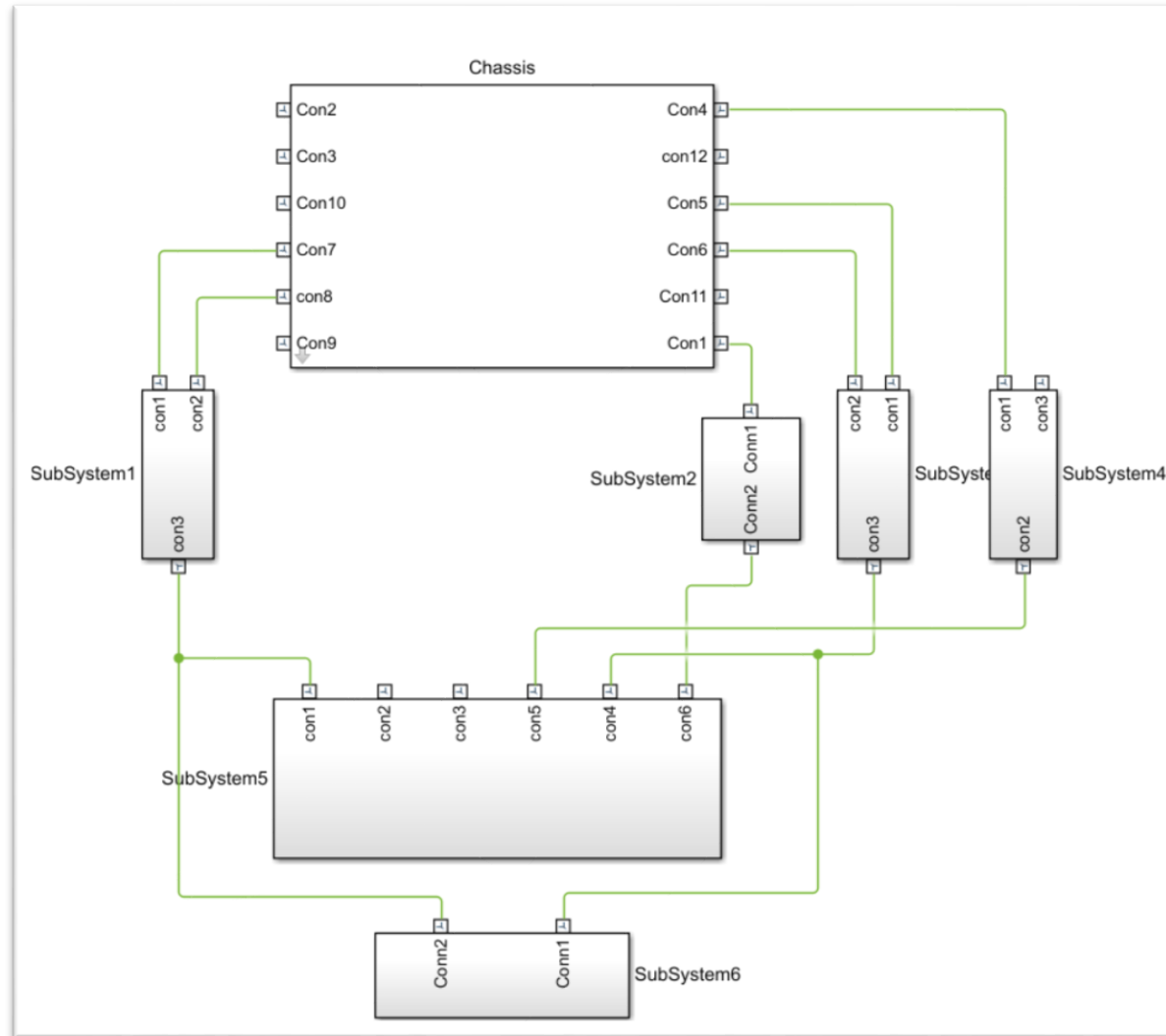

The solution: Virtual testing by Simscape multibody...



Features

- ✓ Parametric model & less no. inputs
- ✓ Design optimization
- ✓ Scalable (2Axle, 3Axle, 4Axle, 5Axle trucks & buses...)
- ✓ Variants in minutes
- ✓ Models inertia, joint friction, stiffness...
- ✓ Highly customizable
- ✓ 100% In-house (No-license fee)

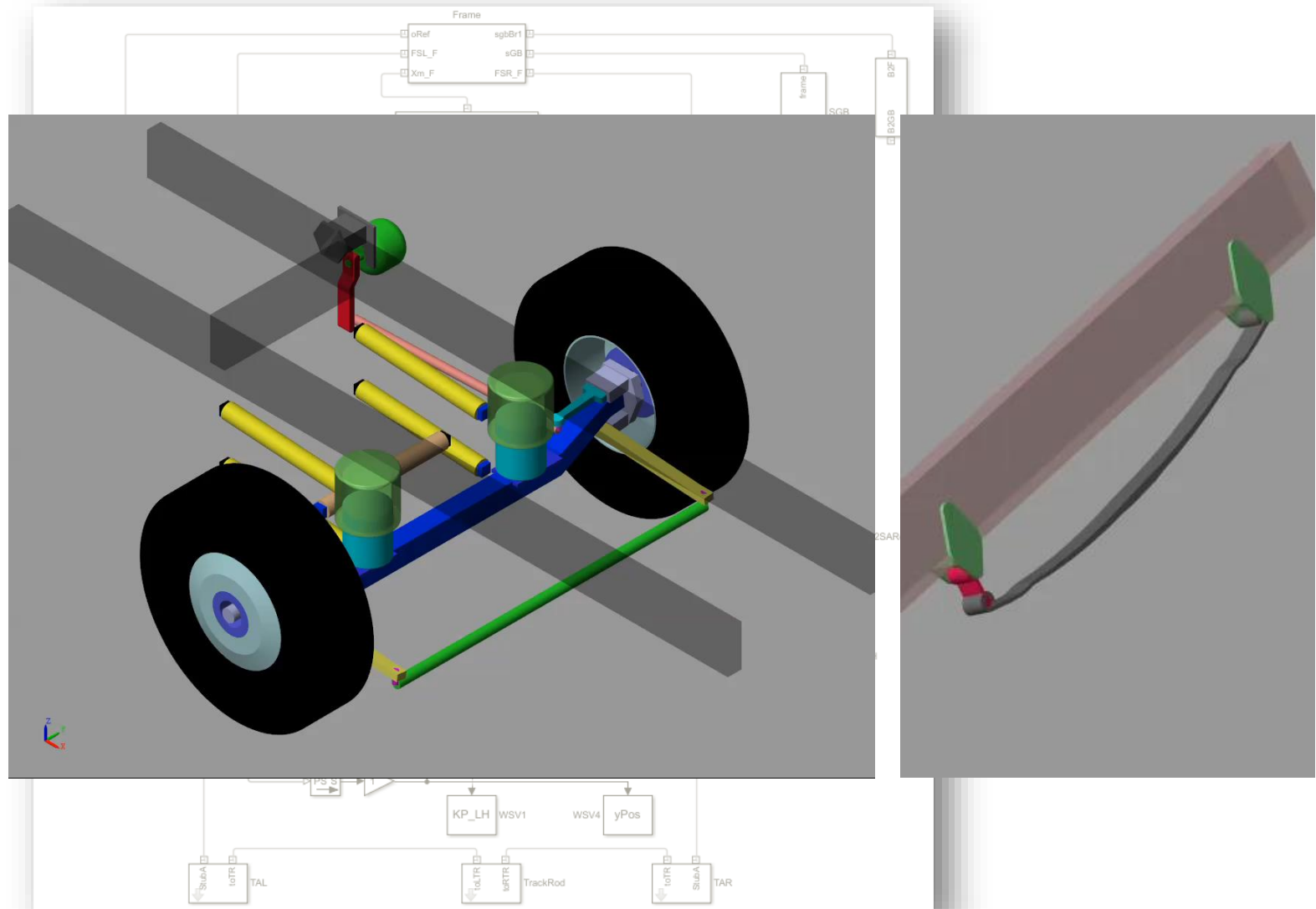

The solution:....Modular virtual testing system delivering needs of system design

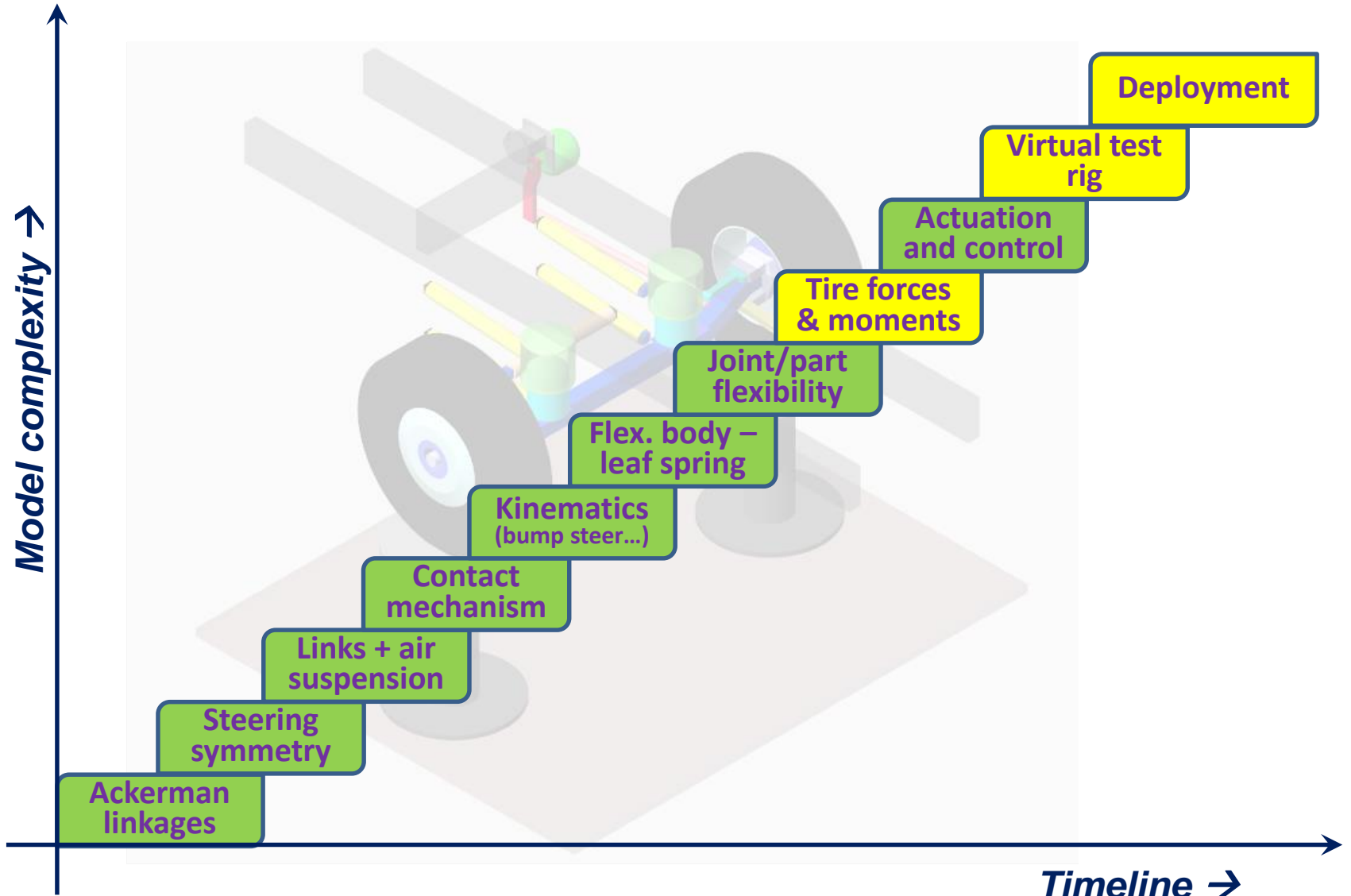

The benefits

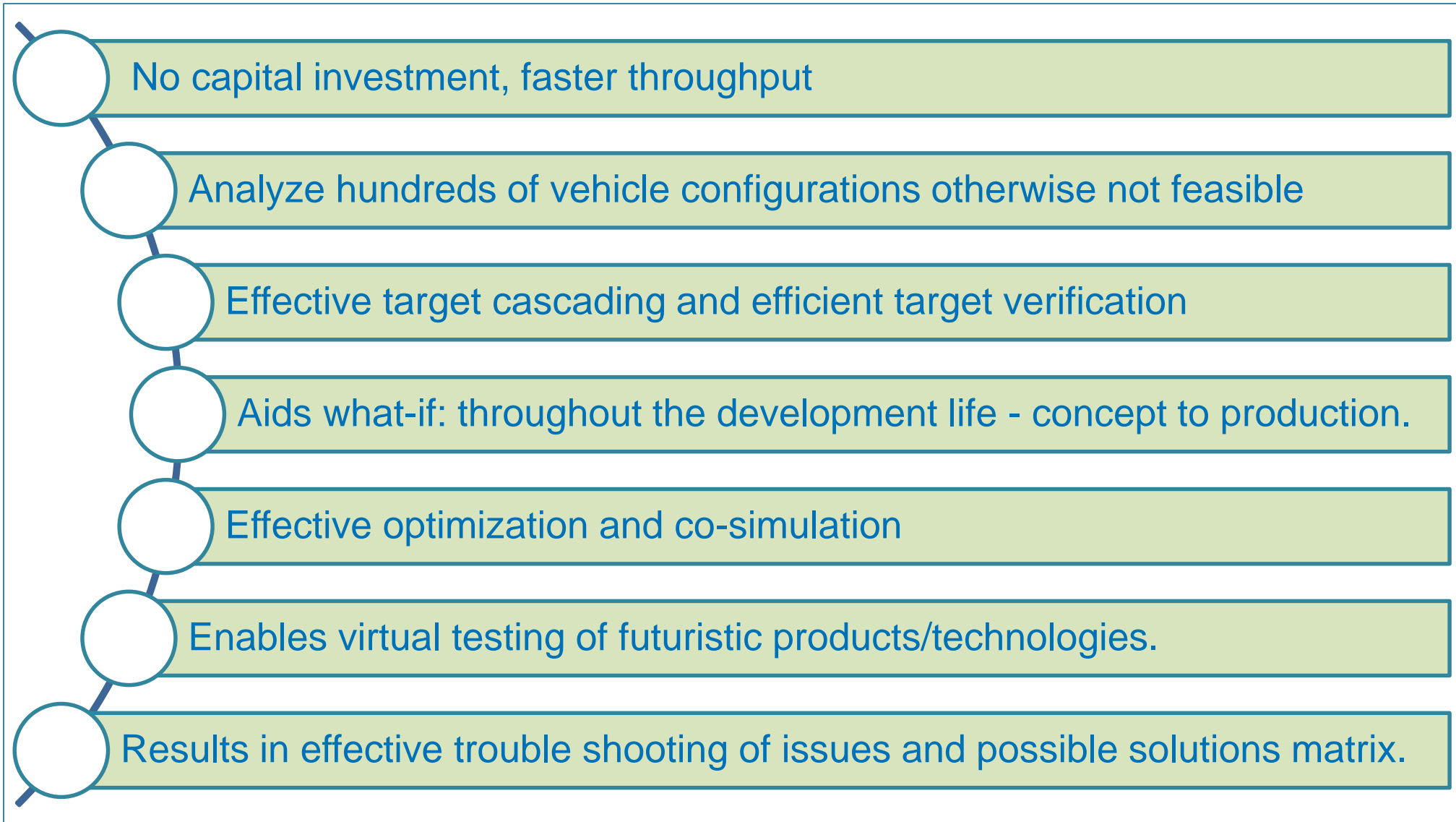



Thank you!